



Rated Power  
Operating Weight  
Bucket Capacity

190.5kW/2000rpm  
33600kg  
1.5m<sup>3</sup>

**FR330D**  
EXCAVATOR





## EFFICIENCY

### Powerful Engine

Equipped with original ISUZU engine imported from Japan which can provide strong power when working with low fuel consumption, the fuel efficiency is improved dramatically.

### Hydraulic System

Kawasaki hydraulic components are adopted, combining with LOVOL Japan Engineering Center's optimal adjustment, the whole hydraulic system delivers smoothness, coordination and fast response features when working. Kawasaki intelligent control system also can make great match between engine and main pump which could improve working efficiency significantly.

### Electronic Control System

The new electronic control system is adopted in order to improve the calculation speed to achieve precise operation. Automatic idle function can reduce fuel consumption and noise dramatically.

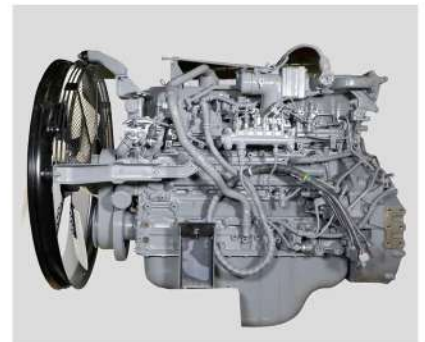

**PT. HASTA KARYA ANANTA**

SALES - RENTAL - SERVICE - SPAREPART - TRADE IN





## RELIABILITY

### Reinforced Structures

The advanced stress analysis technology and Q345 materials make whole structures more reliable. The front and rear support of boom are made of cast steel which effectively reduces concentration of stress, key positions are also reinforced by welding strength plate, which makes arm more robust.

### Reliable Electrical System

All the wiring harnesses adopt waterproof and dustproof connectors, which have high security level and high reliability. Shut-down protection is added to reduce the failure possibility for electrical elements when power was cut off.

### Reinforced Working Device

Adopts high-strength rock bucket teeth which is special suitable for the tough applications, the boom and arm are reinforced to prolong the service life. Self-lubrication shaft sleeve is used to make every linkage works smoothly with high durability.



**PT. HASTA KARYA ANANTA**

SALES - RENTAL - SERVICE - SPAREPART - TRADE IN

## COMFORT



### Large Spacious Cab

Equipped with spacious cab which provides operator large space to operate machine. The premium suspension seat with armrests is very comfortable and it can reduce the working fatigue dramatically. Front windshield can be partially or fully retracted to the cab roof. Rearview camera is optional to get better rear vision in order to improve operation safety in jobsite.

### Ergonomic Design

The proportional joystick delivers sensitivity, accuracy and smoothness in operation. This joystick is specially designed to meet different operating conditions. Intelligent control system is standard which could control diverse attachments such as bucket, hammer, scarifier and hydraulic scissors.

### Low Noise and Low Vibration

In order to reduce work fatigue and improve productivity, the noise inside of cab has been controlled to the lowest level. The cab is attached to the frame with buffer that dampens vibrations and sound levels to enhance operator comfort.

## SERVICEABILITY



### Display Screen

Add trouble code diagnostic and maintenance monitor functions which are convenient for operator to find the failure and do the routine maintenance on time.

### Engine Hood and Panels

The large engine hood enlarges maintenance space for operator to check and maintain the engine. The tool box is big with big opening angle which can put grease bucket and special tools easily. One key can open all locks of machine, it is very convenient for the operator.

### Filters and Maintenance Period

All the filters are fixed at ground level position, it is very convenient to do routine maintenance. The maintenance interval is also extended to save time and cost.





## INCREASE YOUR PRODUCTIVITY AND PROFIT WITH LOVOL ATTACHMNTS

You can easily expand the performance of your machine by utilizing any of the variety of LOVOL Attachments.

Each LOVOL Attachments is designed to fit the weight and horsepower of LOVOL Excavator for improved performance, safety, and stability.



Hydraulic Shear



Hydraulic Hammer



Standard Bucket



**PT. HASTA KARYA ANANTA**

SALES - RENTAL - SERVICE - SPAREPART - TRADE IN

# STANDARD CONFIGURATION



**PT. HASTA KARYA ANANTA**

SALES - RENTAL - SERVICE - SPAREPART - TRADE IN

## Engine

- Turbocharged 6-cylinders water-cooling direct injection type
- Complying with China Stage II emissions
- Automatic idle system
- Engine oil pan drain valve
- Radiator with protective net
- Double filter element
- Air pre-filter
- Air intake heater
- Fan guard

## Hydraulic System

- Automatic hydraulic system (confluence system)
- Anti-swing valve
- Movable arm and bucket rod block valve
- Multi-stage filtration system
- Cylinder buffer device
- Pilot buffer valve (rotary, bucket rod, movable arm)
- Slope anti-rotation device
- Waste oil discharge pipeline

## Electronic Control System

- 24V power supply
- Diagnostic interface
- Emergency stop switch
- Display brightness adjustment
- Maintenance tips
- Automatic diagnostic system
- Automatic idle system
- One-touch pressure augmentation
- Safe stop / start function
- Main power switch
- Anti-theft system
- Engine starting protection
- Multi-language function of monitor
- Top light of cab

## Cab

- Cigar lighter
- Seat belt
- Front sunshade
- Console box
- Escape hammer
- Air conditioner
- Audio device
- Three-stage shock absorber (silicone oil, rubber pad and spring)
- Flexible antenna
- Suspension seat
- Radio (with interfaces of MP3 and USB)
- Hydraulic safety lock
- Sun-protection safety glass
- Floor mat
- Large storage area
- Pull-up front window
- Removable lower windshield
- Sunshade window
- Wipers
- Open skylight

## Swing Platform

- Passage with railing
- Tool box
- Anti-skid plate
- Large pedal
- Large armrest
- Bottom protection plate
- Anti-collision beam
- Tools
- Spares parts

## Chassis

- Fixed chassis
- 600mm, wide three-tooth track shoe



# TECHNICAL SPECIFICATIONS

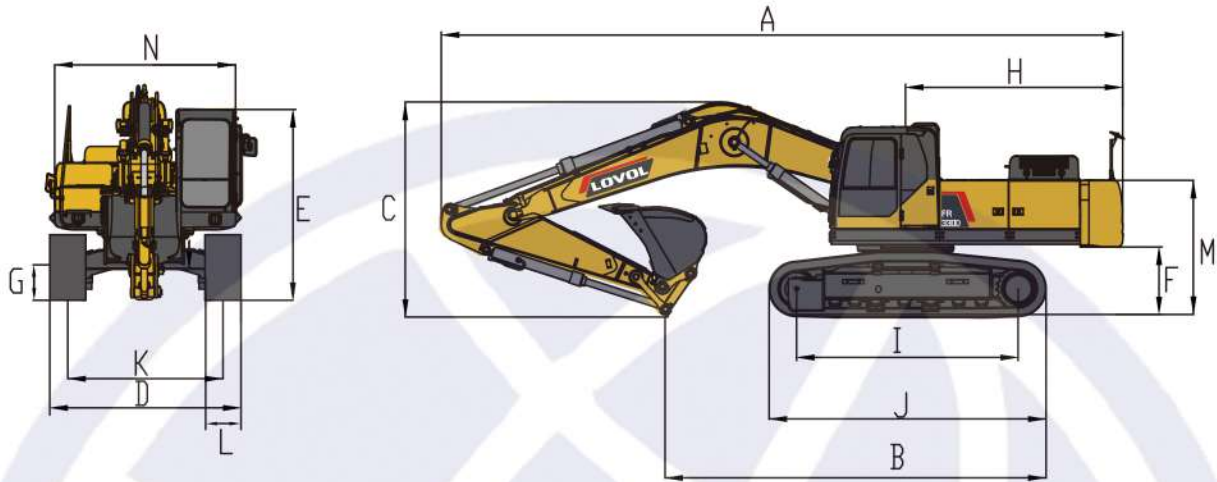

## Working Range



## Dimensions

Max. Digging Height	1	10120mm
Max. Dumping Height	2	7400mm
Max. Digging Depth	3	7330mm
Max. Vertical Digging Depth	4	6365mm
Max. Digging Radius	5	11075mm
Max. Ground Digging Radius	6	10880mm
Min. Turning Radius	7	4320mm

Shipping Length	A	11234mm
Shipping Ground Length	B	5908mm
Boom Height	C	3290mm
Shipping Width	D	3205mm
Cab Height	E	3343mm
Ground Clearance of Counter Weight	F	1205mm
Min. Ground Clearance	G	520mm
Tail Turning Radius	H	3560mm
Wheel Tread	I	3700mm
Track Length	J	4630mm
Track Gauge	K	2590mm
Track Shoe Width	L	600mm
Hood Height	M	2300mm
Rotary Platform Width	N	3205mm

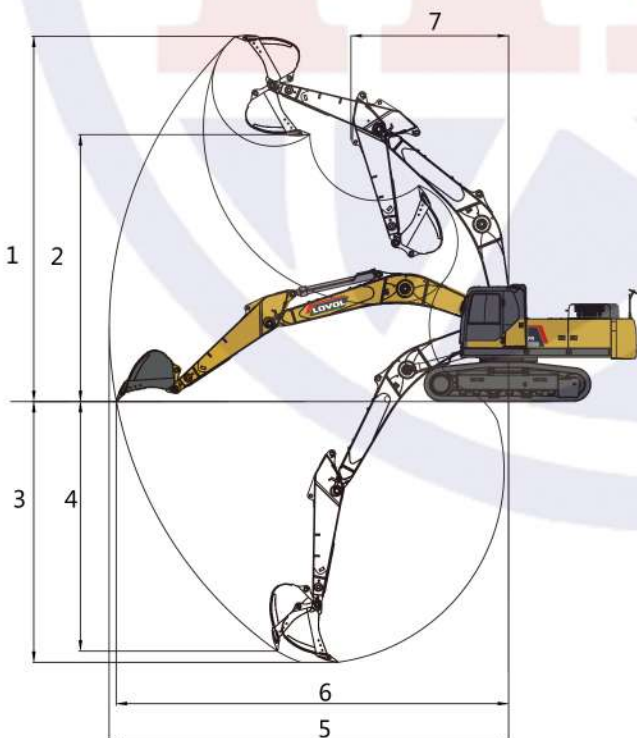

## Other Specifications

Boom Length	6470mm
Arm Length	3190mm
Track Section Number (each side)	45
Track Roller Number	7



# TECHNICAL SPECIFICATIONS



## Engine



## Hydraulic system

Engine Model	ISUZU AA-6HK1XQP
Number of Cylinders	6
Max. Torque/Speed	872.8N·m/1700rpm
Displacement	7.79L

Max. Main Pump Flow	560L/min
Main Safety Valve Pressure	34.3MPa



## Main Performance



## Oil Capacity

Bucket Digging Force	223kN
Arm Digging Force	170kN
Max. Traction Force	290kN
Max. Walking Speed	5.5km/h
Min. Walking Speed	3.3km/h
Rotary Speed	9.2r/min
Gradeability	35°
Ground Pressure	67kPa

Fuel Tank	630L
Hydraulic Tank	340L
Engine Oil	38L

**PT HASTA KARYA ANANTA**

**E-mail: rizky@hka.co.id**

**Tel: +62813 8335 4828**

**Website: www.lifterindo.com**



As manufacturer, LOVOL has right to constantly upgrade and improve our products without informing to customers. The pictures in literatures are for reference only, the detailed specifications are subject to real products.